

SPEC NO.	:	SP030015750-0640
<hr/>		
PART NO.	:	0300130021A0100
<hr/>		
PRODUCT NAME	:	GPS Active ANT/GA-20
<hr/>		
DESCRIPTION	:	1.5D/5M/5V/GT-5
		ROHS Compliant Product
<hr/>		

SPECIFICATION FOR GPS ANTENNA WITH LOW NOISE AMPLIFIER

1.0 SYSTEM:

This antenna system consists of two functional blocks, the LNA portion and the patch antenna.

2.0 GENERAL

2.1 ENVIRONMENTAL CONDITIONS

2.1.1	Operation Temperature	-30°C to + 85°C
2.1.2	Storage Temperatur	-40°C to + 100°C
2.1.3	Relative Humidity	20% to 95%

2.2 ELECTRICAL SPECIFICATIONS

2.2.1	Operation Voltage	Min: 2.5 V	Typ: 3.0 V	Max: 5.5V
2.2.2	Current Consumption	Typ: 13 mA	Max: 18mA	@ 5.0V

2.3 MECHANICAL SPECIFICATIONS

2.3.1	Mounting	Magnet mount.
2.3.2	Horizontal Pulling Force of Magnet	19.6N Min.
2.3.3	Water Proof	Deep into water 100mm, 10 Min.(JIS D0203 D2)
2.3.4	Shock	50G 11sec. Half sine wave. 3 Axes,Every Axes 3 Times.
2.3.5	Vibration	10~200Hz Log. Sweep 3.0G sweep time: 15 Minutes, 3 Axes.
2.3.6	Magnet Threshold	The antenna must stay atatched to the vehicle, at a speed of 180 km/h.

2.3.7	Cable Pulling Off Force	At room temperature Min 5Kg /10sec. Apply 5Kg /10sec pulling force between the cable and the antenna unit, no visible damage shall appear on the cable and connector.
2.3.8	Bending Test	After bending 90° right and left for 1,000 cycles, no permanent damage were found.
2.3.9	Weight	70g Max.
2.3.10	Dimension	See Fig. 2

3.0 ANTENNA

3.1	Frequency Range	1575.42 ± 1.023 MHz.
3.2	Bandwidth	15 MHz min. (Return loss -10 dB)
3.3	Gain	at 90° Elevation: + 2.0 dBic Typ. at 10° Elevation: -1.0 dBic Typ . Mounted on the 70mm*70mm ground plane.
3.4	Polarization	RHCP
3.5	Axial Ratio	at 90° Elevation: 3.0 dB Max. at 10° Elevation: 7.0 dB Max. Mounted on the 70mm*70mm ground plane.

4.0 LNA

4.1	Frequency Range	1575.42±1.023 MHz
4.2	Gain	28dB ±4dB (+ 25 °C ± 5°C) 28dB ±5dB (- 30 °C ± 85°C)
4.3	Noise Figure	1.5 dB Max. (+ 25 °C ± 5°C) @ 5.0V 2.1 dB Max. (- 30 °C ± 85°C) @ 5.0V
4.4	Output Impedance	50 Ω
4.5	Outer Band Attenuation	F0=1575. 42MHz F0±20MHz 7dB min F0±30MHz 12dB min F0±50MHz 20dB min F0±100MHz 30dB min
4.6	Output VSWR	2. 0 Max.

5.0 TOTAL SPECIFICATIONS (Through Antenna, LNA, Cable and Connector)

5.1	RF Cable	1.5DS-QEHV , ϕ 2.9 ± 0.1mm , Black
		Cable Length 5M ± 5cm
5.2	RF Connector	GT5-1S-HU
5.3	Frequency Range	1575.42 ± 1.023MHz
5.4	Gain	26dB ±5dB (+ 25 °C ± 5°C) 26dB ±6dB (-30 °C ± 85°C)
		Mounted on the the 70mm*70m ground plane
5.5	Output Impedance	50 Ω
5.6	VSWR	2.0 Max

6.0 BLOCK DIAGRAM

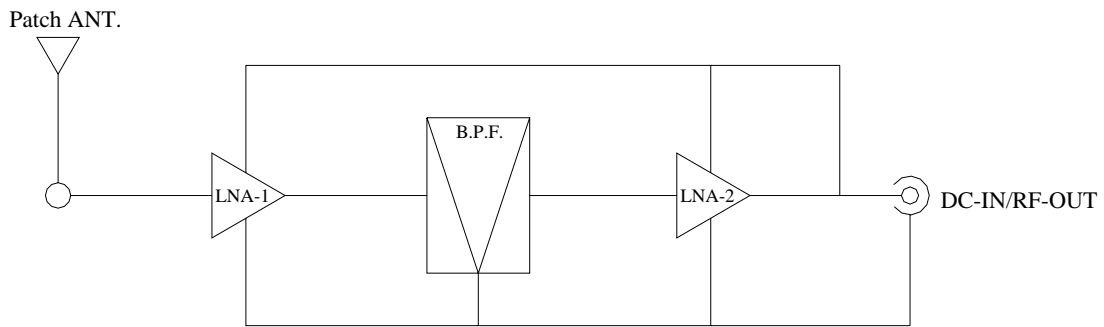

Fig.1

7.0 CAUTIONS

GPS (Global Positioning System) is a satellite-based navigation system. In an unobstructed clear view of the sky, GPS works anywhere in the world, 24 hours a day.

GPS is developed and operated by the government of United States. Under the policy of the government, the degradation in accuracy shall occur without prior warnings, and sometimes satellites don't transmit signal due to adjustment, test, and orbital revision.

Also, please note:

1. products such as motors, computer, and RF devices, which emit high levels of magnetic field and interference, that may cause the performance of the GPS unit to drop.
2. the optimal position during automobile applications is on the roof top of the vehicles. If the GPS antenna unit is to be placed inside the car, be certain to avoid coverage by metal objects for optimal performance.

8.0 OUTLINE

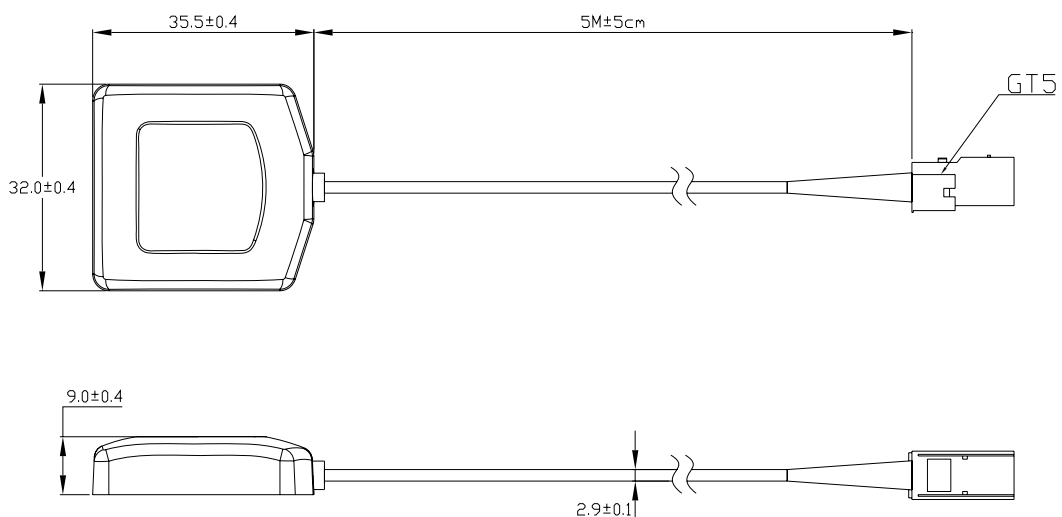

Unit:mm